

High Efficiency eF Series[®] Residential Power Vent Gas Water Heater

The Residential eF Series[®] Model features:

- **ENERGY STAR[®] Qualified**—Meets or exceeds requirements for ENERGY STAR[®] per the latest ENERGY STAR[®] criteria revision, as well as most utility rebate programs.
- **Vertical, Dual-pass Heat Exchanger System**—Highly efficient, helical-finned 5" (127mm) primary heat exchanger tube and three, stainless steel baffled, 2" (51mm) secondary heat exchanger tubes.
 - Vertical design eliminates corrosion protection challenges of condensing water heaters that utilize less durable heat exchanger designs.
- **Self-priming Condensate Tee**—No need for trap installation. Internal condensate trap height appropriate for condensate pump use where necessary.
- **Power Vent**—Powerful yet quiet design for greater resistance to outside winds and greater vent lengths for difficult venting situations through the roof or side wall. 10 ft. (3m) power cord included (120 VAC).
- **Horizontal and Vertical Venting**—With 2", 3" or 4" (51mm, 76mm or 102mm) PVC, ABS, CPVC, or PP.
- **Bradford White ICON System[®]**—Intelligent gas control with spark to pilot ignition system eliminates the constant burning pilot. This results in savings of pilot gas during standby periods (120 VAC).
 - **Enhanced Performance**—Proprietary algorithms provide enhanced First Hour Rating and tighter temperature differential.
 - **Advanced Temperature Control System**—Microprocessor constantly monitors and controls burner operation to maintain consistent and accurate water temperature levels.
 - **Intelligent Diagnostics**—An exclusive green LED light prompts the installer during start-up and provides ten different diagnostic codes to assist in troubleshooting.
 - **Pilot On Indication**—Flashing green LED provides positive indication that pilot is on.
 - **Separate Immersed Thermowell**—High-strength advanced polymer composite thermowell provides isolation between electric temperature sensor and surrounding water. No need to drain the tank when removing gas valve.
- **Factory-Installed Hydrojet[®] Total Performance System**—Sediment reducing device that also increases first hour rating of hot water while minimizing temperature build-up in tank.
- **Vitraglas[®] Lining**—An exclusively engineered enamel formula that provides superior tank protection from the highly corrosive effects of hot water. This formula (Vitraglas[®]) is fused to the steel surface by firing at a temperature of over 1600°F (871°C).
 - Interior and exterior of the three, 2" (51mm) secondary heat exchanger tubes are protected with Vitraglas[®].
- **Insulation System**—2" (51mm) Non-CFC foam insulation covers the sides and top of the tank, reducing heat loss. This results in less energy consumption, improved efficiencies, and jacket rigidity.
- **Pedestal Base.**
- **Water Connections**—3/4" (19mm) NPT factory-installed true dielectric fittings extend water heater life and simplify water line connections.
- **3/4" (19mm) NPT Side Connections.**
- **Factory installed Heat Traps**—Design incorporates a flexible disk that reduces heat loss in piping and eliminates the potential for noise generation.
- **Two Protective Anode Rods.**
- **T&P Relief Valve**—Installed.
- **Low Restrictive Brass Drain Valve.**



Photo is of
RC2PV50H6N

FEATURING:



6 or 10-Year Limited Tank Warranties / 6 or 10-Year Limited Warranty on Component Parts.

For more information on warranty, please visit www.bradfordwhite.com

For products installed in USA, Canada, and Puerto Rico. Some states do not allow limitations on warranties. See complete copy of the warranty included with the heater.

High Efficiency eF Series® Residential Power Vent Gas Water Heater

High Efficiency Model

NATURAL GAS AND LIQUID PROPANE MODELS

Model Number	Nominal Gal. Capacity		DOE Rated Storage Volume (Gal.)	BTU/Hr. Input	LP BTU/Hr. Input	First Hour Rating (Gal.)	Uniform Energy Factor	Recovery at 90°F Rise*				Model Number	Nominal Liter Capacity	DOE Rated Storage Volume (Liters)	kW Input	LP kW Input	First Hour Rating (Liters)	Uniform Energy Factor	Recovery at 50°C Rise*	
	U.S. Gal.	Imp. Gal.						U.S. GPH	Imp. GPH	U.S. GPH	Imp. GPH								Liters/Hour	LP Liters/Hour
★RC2PV50H6N	50	42	49	76,000	76,000	120	0.80	91	77	93	77	★RC2PV50H6N	190	185	22.0	22.0	455	0.80	344	352
Model Number	A Floor to Vent Conn. in.	B Jacket Dia. in.	C Vent Size in.	D Floor to T&P Conn. in.	E Floor to Gas Conn. in.	F Floor to Top of Heater in.	G Floor to Water Conn. in.	H Depth in.	J C/L of Water Conn. in.	K Floor to Space Heating Inlet in.	L Floor to Space Heating Outlet in.	M Water Conn. NPT in.	R Space Heating Conn. Size in.	S Gas Conn. Size in.	Approx. Shipping Weight lbs.					
★RC2PV50H6N	67 ^{7/16}	24	2, 3, and 4	46 ^{3/8}	13 ^{5/8}	56 ^{1/4}	57	32 ^{7/8}	8	15 ^{3/8}	46 ^{3/8}	3/4	3/4	1/2	225					
Model Number	A Floor to Vent Conn. mm.	B Jacket Dia. mm.	C Vent Size mm.	D Floor to T&P Conn. mm.	E Floor to Gas Conn. mm.	F Floor to Top of Heater mm.	G Floor to Water Conn. mm.	H Depth mm.	J C/L of Water Conn. mm.	K Floor to Space Heating Inlet mm.	L Floor to Space Heating Outlet mm.	M Water Conn. NPT mm.	R Space Heating Conn. Size mm.	S Gas Conn. Size mm.	Approx. Shipping Weight kg.					
★RC2PV50H6N	1713	610	51, 76, and 102	1178	346	1429	1448	835	203	397	1178	19	19	13	102					

Propane models feature a Titanium Stabilized Stainless Steel propane burner.

For propane (LP) models, change suffix "N" to "X".

Uniform Energy Factor and First Hour Rating is based on the latest AHRI directory listings.

★ = ENERGY STAR® Qualified.



Optional Condensate Neutralizer Kit: p/n A2123601.

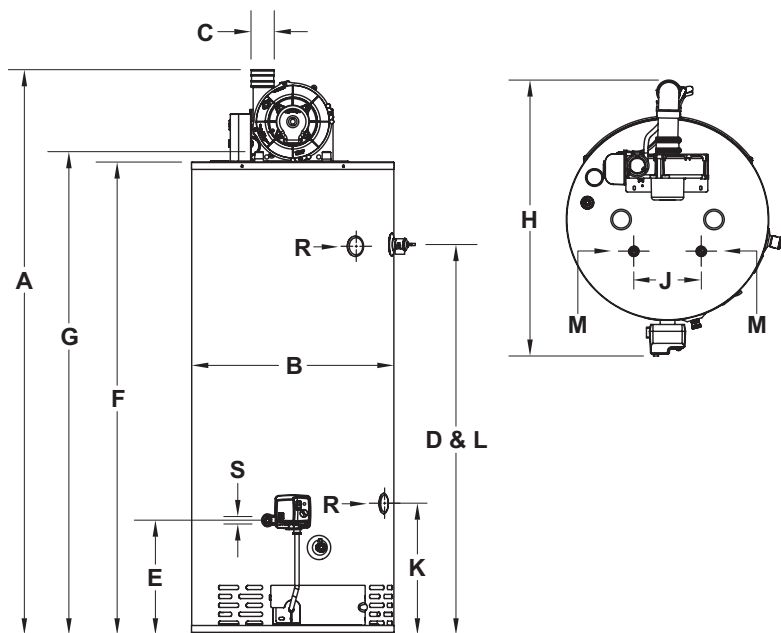

RC2PV50H6N	2" Vent Pipe	3" Vent Pipe	4" Vent Pipe
Max. Equivalent Length	†50 ft.	†120 ft.	†180 ft.
Min. Equivalent Length	7 ft.	15 ft.	15 ft.
Number of 90° Elbows	1: 45 ft. 2: 40 ft. 3: 35 ft.	115 ft. 110 ft. 105 ft.	175 ft. 170 ft. 165 ft.

RC2PV50H6N	51mm Vent Pipe	76mm Vent Pipe	102mm Vent Pipe
Max. Equivalent Length	†15.2m	†36.6m	†55.0m
Min. Equivalent Length	2.1m	4.6m	4.6m
Number of 90° Elbows	1: 13.7m 2: 12.2m 3: 10.7m	35.0m 33.6m 32.0m	53.3m 52.0m 50.3m

Subtract 5 ft. (1.5m) for each additional 90° elbow.
† For high altitude installations, consult the installation instructions.

General:

Meets EPACT Requirements.

All gas water heaters are certified at 300 PSI test pressure (2068 kPa) and 150 PSI working pressure (1034 kPa). All water connections are 3/4" NPT (19mm) on 8" (203mm) centers, all gas connections are 1/2" (13mm). All models design certified by CSA International (formerly AGA/CGA), ANSI standard Z21.10.3 and peak performance rated.

Dimensions and specifications subject to change without notice in accordance with our policy of continuous product improvement.

Suitable for Water (Potable) Heating and Space Heating. Toxic chemicals, such as those used for boiler treatment, shall NEVER be introduced into this system. This unit may NEVER be connected to any existing heating system or component(s) previously used with a non-potable water heating appliance.

— BRADFORD WHITE IS —



Sales: 800-523-2931 ■ Fax 215-641-1612

24/7 Technical Support: 800-334-3393 ■ Email techserv@bradfordwhite.com

Products made by Bradford White are manufactured in the United States using the finest raw materials and components from around the world.

Built to be the Best®